

# WAFFLE HORIZONTAL - 1800x600



Flatline Acoustic Panel Collection is an ideal solution for commercial and educational areas. The Collection promotes personalized and acoustically balanced workspaces without interruption to a collaborative environment. Products can be adjusted and moved to suit the dynamic requirement of a fast-paced modul office. This collection offers acoustic wall panels, ceiling panels, and alternative acoustical solutions.

## SPECIFICATION:

- Composition: 100 % polyester (recycled PET appx. 50 %)
- Material Weight: 1300g /m<sup>2</sup> (+/- 5 %)
- Material Thickness: 6mm Natural & Mandarin colours (+/- 10 %)
- Panel Weight: Natural: 3,30 kg / per pcs. (+/-5%)  
Mandarin: kg / per pcs. (+/-5%)

## PERFORMANCE:

- Acoustic Rates: Natural: 0.55 NRC (EN-11654)  
Mandarin: NRC (EN-11654)  
Natural + Feltfill: 0.95 NRC (EN-11654)  
Mandarin + Feltfill: NRC (EN-11654)
- Fire Rates: B, S1, d0 (EN-13501)
- Light fastness: 6+ (ISO-105 B02)
- Health : 99.9 % Antibacterial (ISO-20743)  
Formaldehyde-free (ISO-14184)
- Moisture Absorption: >0.03 % by weight (50°C/122°F at 90% relative humidity)
- Thermal insulating: 0,040 W/mK
- Abrasion: EN ISO 12947 / Performance 'A'

## KEY FEATURES & BENEFITS:

- Available in 7 Natural colours & 34 Mandarin colours.
- Highly durable providing long-term stability and performance.
- Safe, non-toxic, non-irritant & without red list chemical binders.
- Recycled and recyclable.
- 10 years warranty.

## CARE:

- Easy to clean with a damp cloth or vacuum cleaner.
- Indoor use only.

## INSTALLATION:

- Designed for easy assembly with 2 installation options. With the guidance of the montage template, neodymium magnets or velcro disks are screwed to the surface. Fix the brackets behind the panel to the magnets or velcro disks.

## DIMENSIONS (MM):

L: 1800mm  
H: 600mm  
W: 30mm

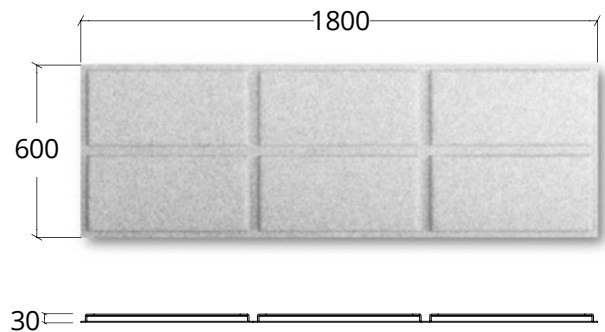

Magnets or Velcro discs

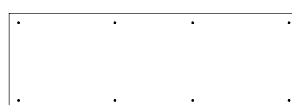

Back Side - Brackets

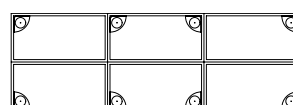

Front Side



# WAFFLE HORIZONTAL - 1800x1200

# NGA

Flatline Acoustic Panel Collection is an ideal solution for commercial and educational areas. The Collection promotes personalized and acoustically balanced workspaces without interruption to a collaborative environment. Products can be adjusted and moved to suit the dynamic requirement of a fast-paced modular office. This collection offers acoustic wall panels, ceiling panels, and alternative acoustical solutions.

## SPECIFICATION:

- Composition: 100 % polyester (recycled PET appx. 50 %)
- Material Weight: 1300g /m<sup>2</sup> (+/- 5 %)
- Material Thickness: 6mm Natural & Mandarin colours (+/- 10 %)
- Panel Weight: Natural: 5,40 kg / per pcs. (+/-5%)  
Mandarin: kg / per pcs. (+/-5%)

## PERFORMANCE:

- Acoustic Rates: Natural: 0.55 NRC (EN-11654)  
Mandarin: NRC (EN-11654)  
Natural + Feltfill: 0.95 NRC (EN-11654)  
Mandarin + Feltfill: NRC (EN-11654)
- Fire Rates: B, S1, d0 (EN-13501)
- Light fastness: 6+ (ISO-105 B02)
- Health : 99.9 % Antibacterial (ISO-20743)
- Formaldehyde-free (ISO-14184)
- Moisture Absorption: >0.03 % by weight (50°C/122°F at 90% relative humidity)
- Thermal insulating: 0,040 W/mK
- Abrasion: EN ISO 12947 / Performance 'A'

## KEY FEATURES & BENEFITS:

- Available in 7 Natural colors & 34 Mandarin colors.
- Highly durable providing long-term stability and performance. Safe, non-toxic, non-irritant & without red list chemical binders. Recycled and recyclable.
- 10 years warranty.

## CARE:

- Easy to clean with a damp cloth or vacuum cleaner.
- Indoor use only.

## INSTALLATION:

- Designed for easy assembly with 2 installation options. With the guidance of the montage template, neodymium magnets or velcro disks are screwed to the surface. Fix the brackets behind the panel to the magnets or velcro disks.

Magnets or Velcro discs



Back Side - Brackets

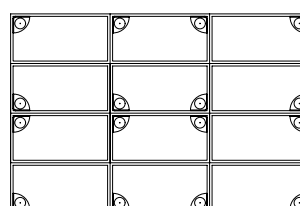

Front Side

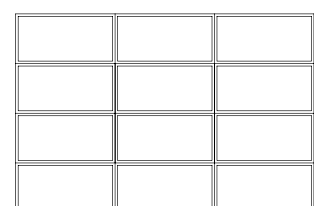

## DIMENSIONS (MM):

L: 1800mm  
H: 1200mm  
W: 30mm

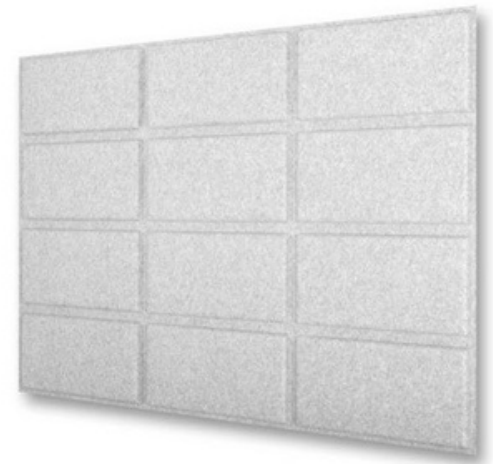
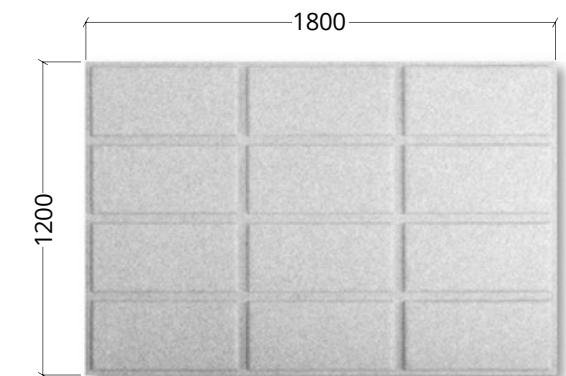

# WAFFLE LAY-IN

# NGA

Flatline Acoustic Panel Collection is an ideal solution for commercial and educational areas. The Collection promotes personalized and acoustically balanced workspaces without interruption to a collaborative environment. Products can be adjusted and moved to suit the dynamic requirement of a fast-paced modular office. This collection offers acoustic wall panels, ceiling panels, and alternative acoustical solutions.

## SPECIFICATION:

- Composition: 100 % polyester (recycled PET appx. 50 %)
- Material Weight: 1300g /m<sup>2</sup> (+/- 5 %)
- Material Thickness: 6mm Natural & Mandarin colors (+/- 10 %)
- Panel Weight: 595x595mm / Natural: 0,65 kg / per pcs. (+/-5%)  
595x595mm / Mandarin: 0,90 kg / per pcs. (+/-5%)  
595x1195m / Natural: 1,00 kg / per pcs. (+/-5%)  
595x1195mm / Mandarin: 1,25 kg / per pcs. (+/-5%)

## PERFORMANCE:

- Fire Rates: B, S1, d0 (EN-13501)
- Light fastness: 6+ (ISO-105 B02)
- Health : 99.9 % Antibacterial (ISO-20743)
- Formaldehyde-free (ISO-14184)
- Moisture Absorption: >0.03 % by weight (50°C/122°F at 90% relative humidity)
- Thermal insulating: 0,040 W/mK
- Abrasion: EN ISO 12947 / Performance 'A'

## KEY FEATURES & BENEFITS:

- Available in 7 Natural colours & 34 Mandarin colours.
- Highly durable providing long-term stability and performance.
- Safe, non-toxic, non-irritant & without red list chemical binders.
- Recycled and recyclable.
- 10 years warranty.

## CARE:

- Easy to clean with a damp cloth or vacuum cleaner.
- Indoor use only.

## INSTALLATION:

- Designed for easy assembly with the T24 / T15 Ceiling system.

## DIMENSIONS (MM):

FL650

L: 595mm

H: 595mm

W: 30mm

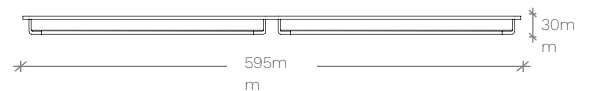

FL651

L: 595mm

H: 1195mm

W: 30mm

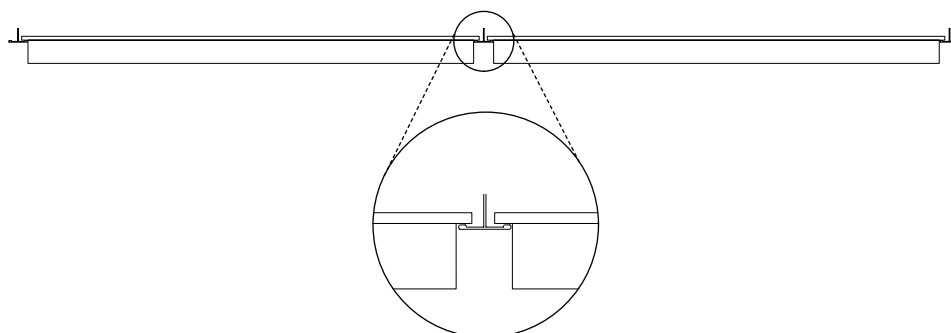
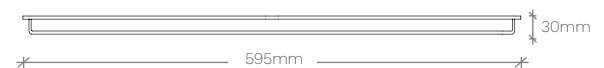

# WAFFLE VERTICAL 1800x1200

# NGA

Flatline Acoustic Panel Collection is an ideal solution for commercial and educational areas. The Collection promotes personalized and acoustically balanced workspaces without interruption to a collaborative environment. Products can be adjusted and moved to suit the dynamic requirement of a fast-paced modular office. This collection offers acoustic wall panels, ceiling panels, and alternative acoustical solutions.

## SPECIFICATION:

- Composition: 100 % polyester (recycled PET appx. 50 %) Material
- Weight: 1300g /m<sup>2</sup> (+/- 5 %)
- Material Thickness: 6mm Natural & Mandarin colors (+/- 10 %)
- Panel Weight: Natural: 5,40 kg / per pcs. (+/-5%)  
Mandarin: kg / per pcs. (+/-5%)

## PERFORMANCE:

- Acoustic Rates: Natural: 0.55 NRC (EN-11654)  
Mandarin: NRC (EN-11654)  
Natural + Feltfill: 0.95 NRC (EN-11654)  
Mandarin + Feltfill: NRC (EN-11654)
- Fire Rates: B, S1, d0 (EN-13501)
- Light fastness: 6+ (ISO-105 B02)
- Health : 99.9 % Antibacterial (ISO-20743)
- Formaldehyde-free (ISO-14184)
- Moisture Absorption: >0.03 % by weight (50°C/122°F at 90% relative humidity)
- Thermal insulating: 0,040 W/mK
- Abrasion: EN ISO 12947 / Performance 'A'

## KEY FEATURES & BENEFITS:

- Available in 7 Natural colors & 34 Mandarin colors.
- Highly durable providing long-term stability and performance. Safe, non-toxic, non-irritant & without red list chemical binders. Recycled and recyclable.
- 10 years warranty.

## CARE:

- Easy to clean with a damp cloth or vacuum cleaner.
- Indoor use only.

## INSTALLATION:

- Designed for easy assembly with 2 installation options. With the guidance of the montage template, neodymium magnets or velcro disks are screwed to the surface. Fix the brackets behind the panel to the magnets or velcro disks.

## DIMENSIONS (MM):

L: 1800mm  
H: 1200mm  
W: 30mm

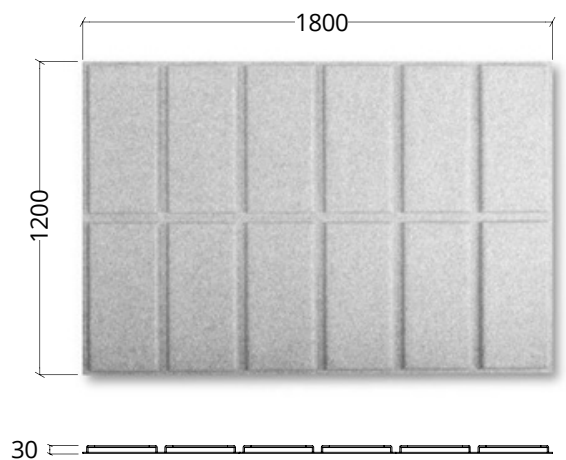

Magnets or Velcro discs



Back Side - Brackets

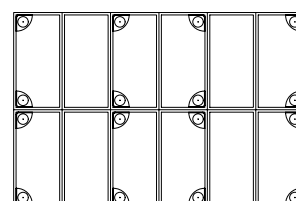

Front Side

