

CRACKER CLOUD LIGHTING

800x2400

NGA

SPECIFICATION

- Composition: 100 % polyester (recycled PET appx. 50 %)
- Material Weight: 1300g /m² (+/- 5 %)
- Material Thickness: 6mm Natural & Mandarin colours (+/- 10 %)
- Panel Weight: Natural: 8,62 kg / per pcs. (+/-5%)
Mandarin: 9,29 kg / per pcs. (+/-5%)

L: 1200mm
W: 800mm
H: 65mm

Lamp
Dimension
L: 2200mm
Ø: 30mm

PERFORMANCE

- Acoustic Rates: Natural: 0.70 NRC (EN-11654)
Mandarin: 0.90 NRC (EN-11654)
Natural + Feltfill: 0.80 NRC (EN-11654)
Mandarin + Feltfill: 1.00 NRC (EN-11654)
- Fire Rates: B, S1, d0 (EN-13501)
- Light fastness: 6+ (ISO-105 B02)
- Health : 99.9 % Antibacterial (ISO-20743)
- Formaldehyde-free (ISO-14184)
- Moisture Absorption: >0.03 % by weight (50°C/122°F at 90% relative humidity)
- Thermal insulating: 0,040 W/mK
- Abrasion: EN ISO 12947 / Performance 'A'

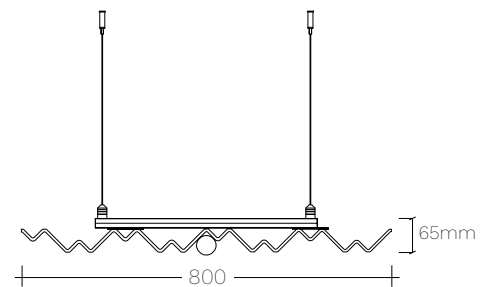
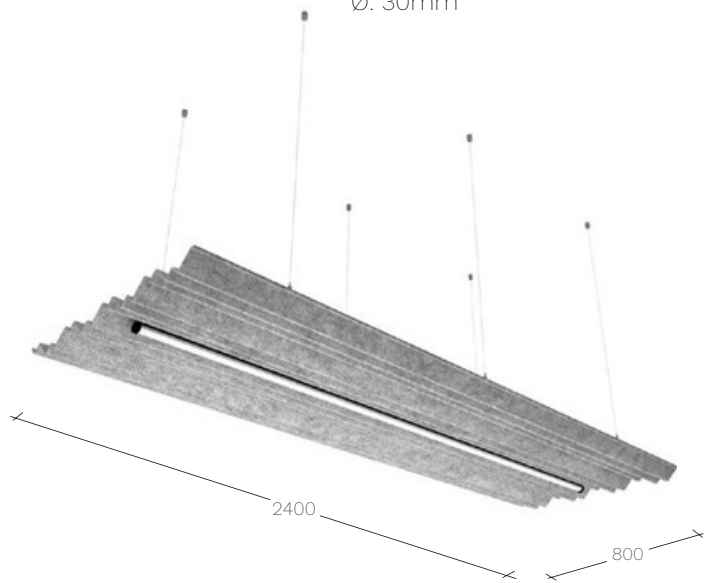

KEY FEATURES & BENEFITS

- Available in 7 Natural colors & 34 Mandarin colors.
- Highly durable providing long-term stability and performance.
- Safe, non-toxic, non-irritant & without red list chemical binders.
- Recycled and recyclable.
- 10 years warranty.

CARE

- Easy to clean with a damp cloth or vacuum cleaner.
- Indoor use only.

INSTALLATION

- Designed for easy assembly with adjustable ceiling mount units.

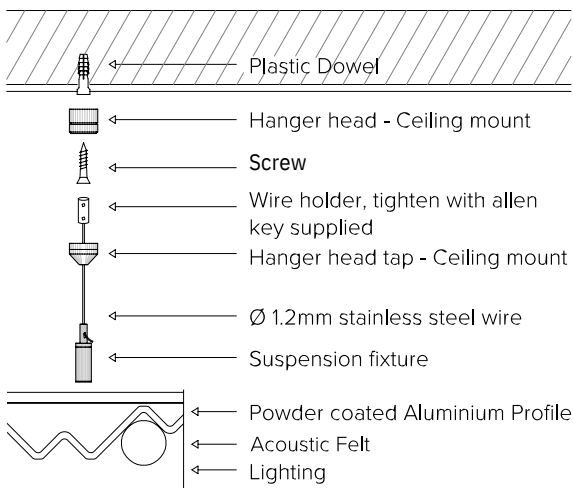

Light Source Specifications

Wattage	22W
Input Voltage	220 - 240V AC
Frequency	50 / 60 Hz
Lumen Output	2090lm
Color Temperature	2700K, 3000K, 4000K
Color Rendering	90CRI
Index Unified Glare	-
Rating	Standard On/Off
Control Type Dimmable (Optional)	DALI, Push Dim, Bluetooth options
Lighting Type	Direct Lighting

CRACKER CLOUD LIGHTING 800x1200



SPECIFICATION

- Composition: 100 % polyester (recycled PET appx. 50 %)
- Material Weight: 1300g /m² (+/- 5 %)
- Material Thickness: 6mm Natural & Mandarin colours (+/- 10 %)
- Panel Weight: Natural: 4,66 kg / per pcs. (+/-5%)
Mandarin: 4,99 kg / per pcs. (+/-5%)

PERFORMANCE

- Acoustic Rates: 3,46 Sabin (m) 250-4000Hz Fire Rates: B, S1,
- d0 (EN-13501)
- Light fastness: 6+ (ISO-105 B02)
- Health : 99.9 % Antibacterial (ISO-20743)
- Formaldehyde-free (ISO-14184)
- Moisture Absorption: >0.03 % by weight (50°C/122°F at 90% relative humidity)
- Thermal insulating: 0,040 W/mK
- Abrasion: EN ISO 12947 / Performance 'A'

KEY FEATURES & BENEFITS

- Available in 7 Natural colors & 34 Mandarin colors.
- Highly durable providing long-term stability and performance.
- Safe, non-toxic, non-irritant & without red list chemical binders.
- Recycled and recyclable.
- 10 years warranty.

CARE

- Easy to clean with a damp cloth or vacuum cleaner.
- Indoor use only.

INSTALLATION

- Designed for easy assembly with adjustable ceiling mount units.

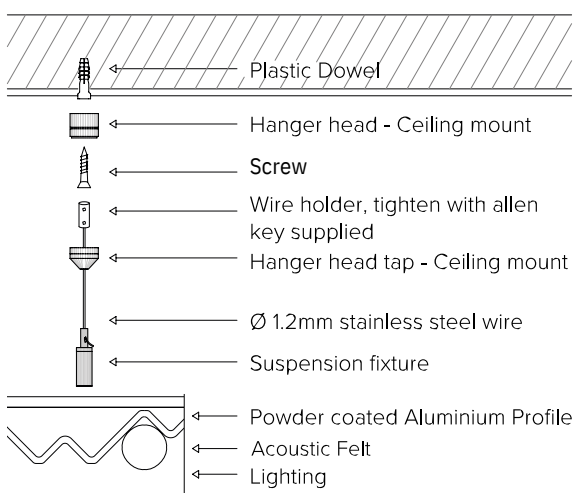

DIMENSIONS (MM):

- | | |
|-----------|----------------|
| L: 1200mm | Lamp Dimension |
| W: 800mm | L: 1000mm |
| H: 65mm | Ø: 30mm |

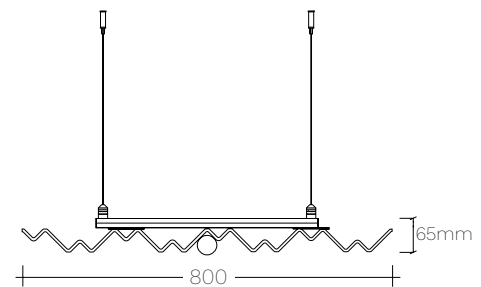
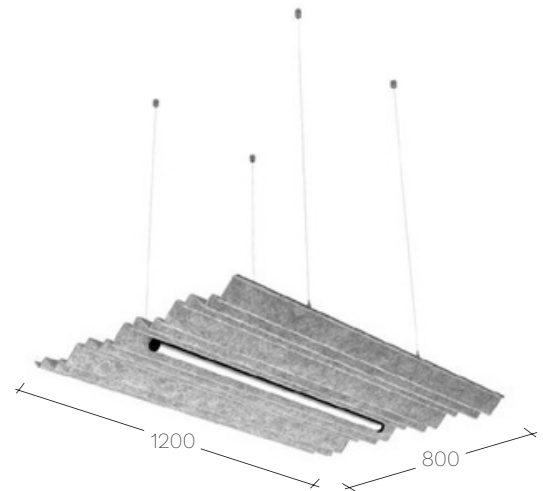

Light Source Specifications	
Wattage	22W
Input Voltage	220 - 240V AC
Frequency	50 / 60 Hz
Lumen Output	2090lm
Color Temperature	2700K, 3000K, 4000K
Color Rendering	90CRI
Index Unified Glare	-
Rating	Standard On/Off
Control Type Dimmable (Optional)	DALI, Push Dim, Bluetooth options
Lighting Type	Direct Lighting