

# SUN MESH HANGING



## SPECIFICATION

- Composition: 100 % polyester (recycled PET appx. 50 %)
- Material Weight: 6mm: 1300g/m<sup>2</sup> (+/- 5 %), 8mm: 1700g/m<sup>2</sup> (+/- 5 %)
- Material Thickness: 6mm Natural & Mandarin colors (+/- 10 %)
- Panel Weight:
  - Natural: 6mm: 1200x2400mm: 4,00 kg / per pcs. (+/- 5 %)
  - 8mm: 1200x2400mm: kg / per pcs. (+/- 5 %)
  - Mandarin: 6mm: 1200x2400mm: 5,50 kg / per pcs. (+/- 5 %)
  - 8mm: 1200x2400mm: kg / per pcs. (+/- 5 %)

## DIMENSIONS (MM):

MSH290H  
W: 1200mm  
L: 2400mm

## PERFORMANCE

- Acoustic Rates: 0,23 NRC (EN11654)
- Fire Rates: B, S1, d0 (EN-13501)
- Light fastness: 6+ (ISO-105 B02)
- Health : 99.9 % Antibacterial (ISO-20743)
- Formaldehyde-free (ISO-14184)
- Moisture Absorption: >0.03 % by weight (50°C/122°F at 90% relative humidity)
- Thermal insulating: 0,040 W/mK
- Abrasion: EN ISO 12947 / Performance 'A'

## KEY FEATURES & BENEFITS

- Available in 7 Natural colors & 34 Mandarin colors.
- Highly durable providing long-term stability and performance.
- Safe, non-toxic, non-irritant & without red list chemical binders.
- Recycled and recyclable.
- 10 years warranty.

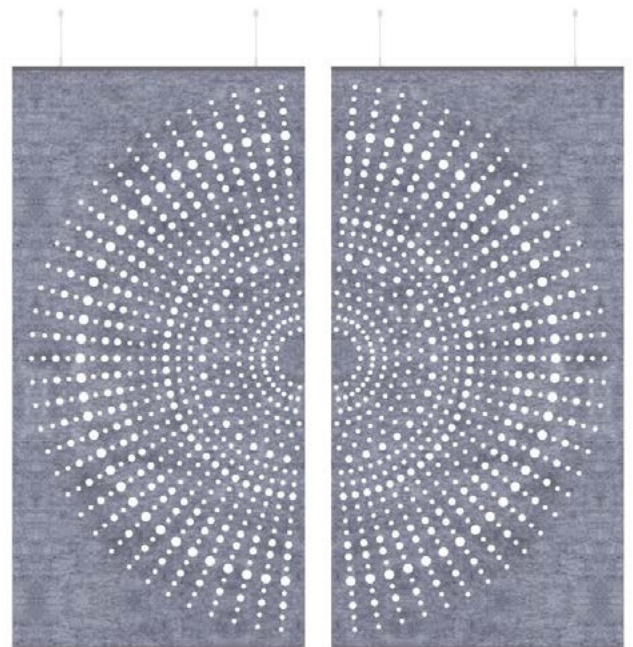

## CARE

- Easy to clean with a damp cloth or vacuum cleaner.
- Indoor use only.

## INSTALLATION

- Individually hanging mesh panel system.

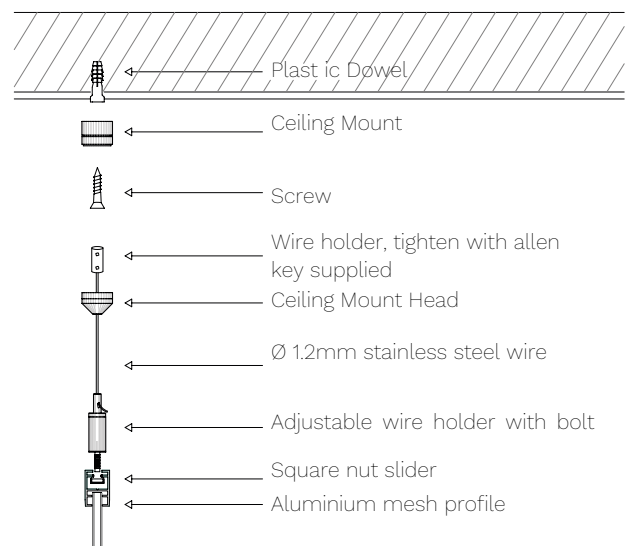
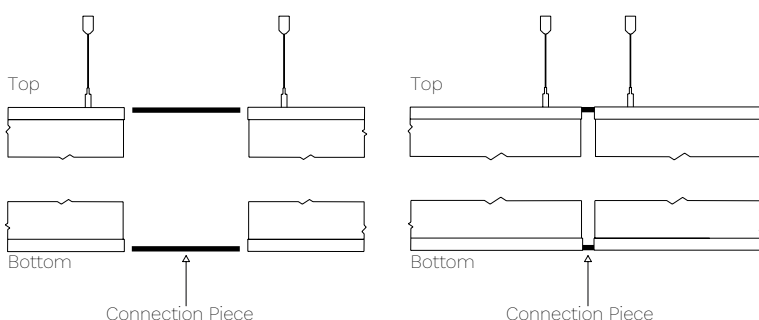

# SUN MESH TRACKING

# NGA

## SPECIFICATION

- Composition: 100 % polyester (recycled PET appx. 50 %)
- Material Weight: 6mm: 1300g/m<sup>2</sup> (+/- 5 %), 8mm: 1700g/m<sup>2</sup> (+/- 5 %)
- Material Thickness: 6mm Natural & Mandarin colors (+/- 10 %)
- Panel Weight:
  - Natural: 6mm: 1200x2400mm: 4,00 kg / per pcs. (+/- 5 %)
  - 8mm: 1200x2400mm: kg / per pcs. (+/- 5 %)
  - Mandarin: 6mm: 1200x2400mm: 5,50 kg / per pcs. (+/- 5 %)
  - 8mm: 1200x2400mm: kg / per pcs. (+/- 5 %)

## DIMENSIONS (MM):

MSH290H  
W: 1200mm  
L: 2400mm

## PERFORMANCE

- Acoustic Rates: 0,23 NRC (EN11654)
- Fire Rates: B, S1, d0 (EN-13501)
- Light fastness: 6+ (ISO-105 B02)
- Health : 99.9 % Antibacterial (ISO-20743)
- Formaldehyde-free (ISO-14184)
- Moisture Absorption: >0.03 % by weight (50°C/122°F at 90% relative humidity)
- Thermal insulating: 0,040 W/mK
- Abrasion: EN ISO 12947 / Performance 'A'

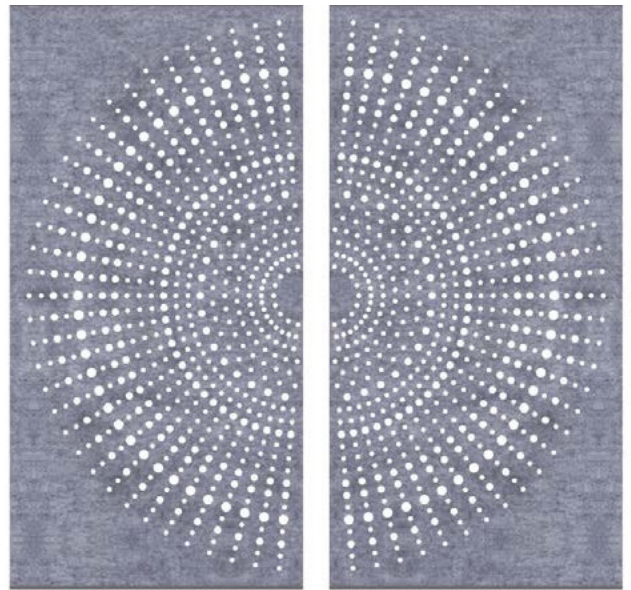

## KEY FEATURES & BENEFITS

- Available in 7 Natural colors & 34 Mandarin colors.
- Highly durable providing long-term stability and performance.
- Safe, non-toxic, non-irritant & without red list chemical binders.
- Recycled and recyclable.
- 10 years warranty.

## CARE

- Easy to clean with a damp cloth or vacuum cleaner.
- Indoor use only.

## INSTALLATION

- Individually hanging mesh panel system.

