

AFRICAN MESH - HANGING



SPECIFICATION

- Composition: 100 % polyester (recycled PET appx. 50 %)
- Material Weight: 6mm: 1300g/m² (+/- 5 %), 8mm: 1700g/m² (+/- 5 %)
- Material Thickness: 6mm Natural & Mandarin colors (+/- 10 %)
- Panel Weight:
 - Natural / 6mm: 800x2400mm: 2,50 kg / per pcs. (+/- 5 %)
 - 1200x2400mm: 4,00 kg / per pcs. (+/- 5 %)
 - 8mm: 800x2400mm: kg / per pcs. (+/- 5 %)
 - 1200x2400mm: kg / per pcs. (+/- 5 %)
 - Mandarin / 6mm: 800x2400mm: 3,50 kg / per pcs. (+/- 5 %)
 - 1200x2400mm: 5,50 kg / per pcs. (+/- 5 %)
 - 8mm 800x2400mm: kg / per pcs. (+/- 5 %)
 - 1200x2400mm: kg / per pcs. (+/- 5 %)

PERFORMANCE

- Acoustic Rates: 0,23 NRC (EN11654)
- Fire Rates: B, S1, d0 (EN-13501)
- Light fastness: 6+ (ISO-105 B02)
- Health : 99.9 % Antibacterial (ISO-20743)
- Formaldehyde-free (ISO-14184)
- Moisture Absorption: >0.03 % by weight (50°C/122°F at 90% relative humidity)
- Thermal insulating: 0,040 W/mK
- Abrasion: EN ISO 12947 / Performance 'A'

KEY FEATURES & BENEFITS

- Available in 7 Natural colors & 34 Mandarin colors.
- Highly durable providing long-term stability and performance.
- Safe, non-toxic, non-irritant & without red list chemical binders.
- Recycled and recyclable.
- 10 years warranty.

CARE

- Easy to clean with a damp cloth or vacuum cleaner.
- cleaner. Indoor use only.

INSTALLATION

- Individually hanging mesh panel system.

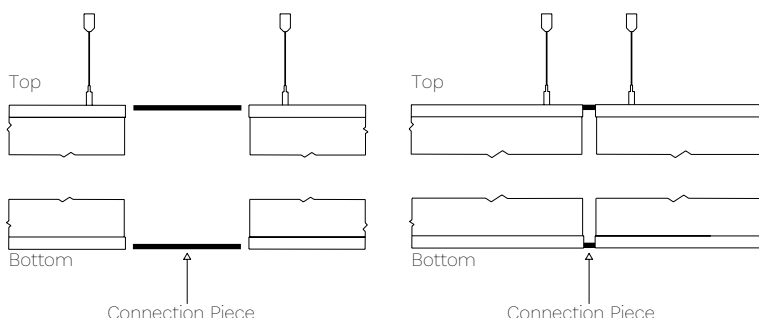

DIMENSIONS (MM):

MSH295H	MSH296H
W: 800mm	W: 1200mm
L: 2400mm	L: 2400mm

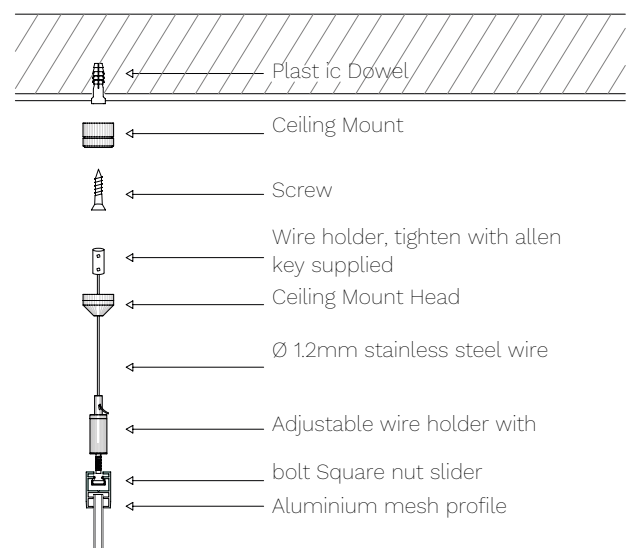
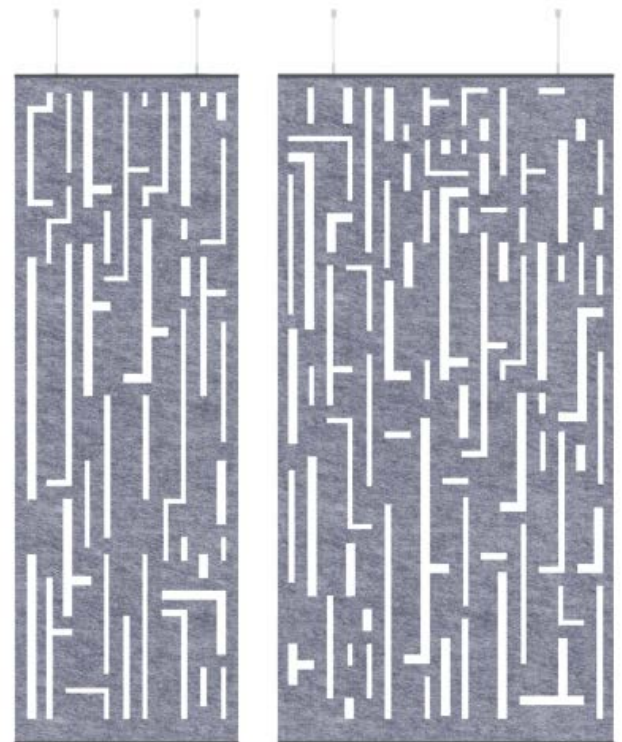

AFRICAN MESH TRACKING



SPECIFICATION

- Composition: 100 % polyester (recycled PET appx. 50 %)
- Material Weight: 6mm: 1300g/m² (+/- 5 %), 8mm: 1700g/m² (+/- 5 %)
- Material Thickness: 6mm Natural & Mandarin colors (+/- 10 %)
- Panel Weight:
 - Natural / 6mm: 800x2400mm: 2,50 kg / per pcs. (+/- 5 %)
 - 1200x2400mm: 4,00 kg / per pcs. (+/- 5 %)
 - 8mm: 800x2400mm: kg / per pcs. (+/- 5 %)
 - 1200x2400mm: kg / per pcs. (+/- 5 %)
 - Mandarin / 6mm 800x2400mm: 3,50 kg / per pcs. (+/- 5 %)
 - 1200x2400mm: 5,50 kg / per pcs. (+/- 5 %)
 - 8mm 800x2400mm: kg / per pcs. (+/- 5 %)
 - 1200x2400mm: kg / per pcs. (+/- 5 %)

PERFORMANCE

- Acoustic Rates: 0,23 NRC (EN11654)
- Fire Rates: B, S1, d0 (EN-13501)
- Light fastness: 6+ (ISO-105 B02)
- Health : 99.9 % Antibacterial (ISO-20743) Formaldehyde-free (ISO-14184)
- Moisture Absorption: >0.03 % by weight (50°C/122°F at 90% relative humidity)
- Thermal insulating: 0,040 W/mK
- Abrasion: EN ISO 12947 / Performance 'A'

KEY FEATURES & BENEFITS

- Available in 7 Natural colors & 34 Mandarin colors.
- Highly durable providing long-term stability and performance.
- Safe, non-toxic, non-irritant & without red list chemical binders.
- Recycled and recyclable.
- 10 years warranty.

CARE

- Easy to clean with a damp cloth or vacuum
- cleaner. Indoor use only.

INSTALLATION

- Individually hanging mesh panel system.

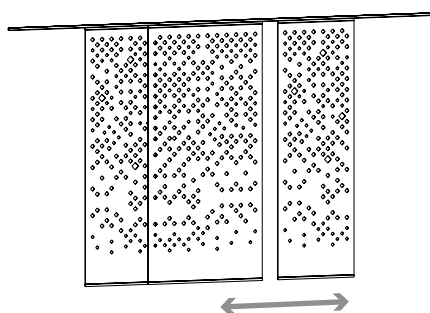

DIMENSIONS (MM):

MSH295H	MSH296H
W: 800mm	W: 1200mm
L: 2400mm	L: 2400mm

